

**bhi**



bhi Ltd  
PO Box 318  
Burgess Hill  
West Sussex  
RH15 9NR

tel: +44 (0)845 217 9926  
fax: +44 (0)845 217 9936

sales@bhi-ltd.com  
www.bhi-ltd.com

**bhi**

**NEDSP1061-KBD**

**Noise Eliminating PCB Module**

**Installation  
and  
Operating Manual**



Includes detailed fitting instructions for  
Yaesu FT-817, Icom 706 MKII G  
and Kenwood TS50

**1061-110D  
Issue E**

DSP Noise Cancellation Products from bhi

DSP Noise Cancellation Products from bhi

## Important Information

### Copyright

This publication, including all photographs and illustrations is protected under international copyright laws, with all rights reserved. Neither this manual, nor any of the material within, may be copied or reproduced without the written consent of bhi Ltd.

### Disclaimer

The information in this document is subject to change without notice. bhi Ltd. makes no representations or warranties with respect to the contents hereof and specifically disclaims any implied warranties of merchantability or fitness for any particular purpose. Furthermore, bhi Ltd. reserves the right to revise this publication and to make changes from time to time in the content hereof without obligation of bhi Ltd. to notify any person of such revision or changes.

The fitting of the bhi NEDSP1061-KBD module may involve the removal of small surface mount components and the drilling out of the transceivers' case. This should only be carried out by a qualified engineer. bhi accepts no responsibility for the fitting or installation of the NEDSP1061-KBD module and are not liable for any damage to equipment caused by its fitment. Fitting this module may invalidate your warranty.

All attempts have been made to ensure that this information is up to date. It is possible that these instructions contain errors, or the equipment is slightly different to the one used to compile this information. In all cases it is up to the installer to ensure that the module is fitted correctly.

By installing this module you are doing so at your own risk.

### NEIM1031 MKII In-line module.

The **NEIM1031 MKII** provides a flexible solution to noise reduction and easily fits between your quipment and speaker.

#### Features:

- Fully adaptive noise cancellation 9 -35dB
- 8 user selectable noise cancellation levels
- Mono earpiece socket
- Input sensitivity control
- Noise cancellation On/Off switch
- Line level in/out
- Input overload indication
- Power on/off with audio bypass.



### NEIM1031 accessories.



#### LSPKR

20 Watt 4 ohm extension speaker for use with the NEIM1031. Fitted with a 3.5mm mono jack plug.



#### 1031-STAND

Perspex mounting stand for the NEIM1031. Allows the NEIM1031 to be mounted for a more comfortable operating position.

**1030-UKPA** UK DC power adapter

**1030-EUPA** European DC power adapter

### Amplified DSP modules.

Easy to install retrofit for existing equipment and extension speakers or older tranceivers.

#### NEDSP1062-PCB:

Basic amplified DSP module.

#### NEDSP1062 - KBD:

Amplified DSP module controlled by a 2 button keyboard.

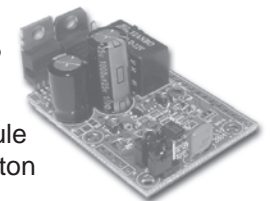

# Appendix D

## Other bhi products

Other noise cancellation products from bhi. Visit [www.bhi-ltd.com](http://www.bhi-ltd.com) for more information.

### 6.1 NES10-2 MK3 Noise Eliminating speaker.

Amplified DSP noise cancellation speaker with new rot filter select knob and increased audio power.

#### Features:

- Fully adaptive noise cancellation 9 -35dB
- 8 user selectable noise cancellation levels
- Mono earpiece socket
- Input sensitivity control
- Noise cancellation On/Off switch
- LED indication of power and noise cancellation
- 12-24VDC operation
- On/Off audio bypass switch.
- Easy to install with adjustable mounting bracket
- 2m audio lead
- Optional extras available.



### 6.2 DSPKR

#### Superb 10 Watt rms audio DSP noise cancelling speaker

#### Features:

- 7 DSP filter levels 9 - 24dB
- 12-18V DC operation
- Simple control of all functions
- sleep mode - Filter store function
- Volume control - Input level indicator
- Comes with 2m audio lead, Fused DC power lead & manual



### 1042 switch box.

Allows up to 6 pieces of equipment to be connected to one speaker or inline module. 3 inputs loaded at 8 ohms.



### Packing List:

Other noise cancellation products from bhi. Visit [www.bhi-ltd.com](http://www.bhi-ltd.com) to check the contents of the box. Please check the contents of the box.

- Operating manual
- NEDSP1061-KBD assembly
- 'Z' bracket
- Self adhesive mounting pads
- bhi NEDSP keyboard label

To install this module you will need the following additional items:

- service manual/circuit diagram of the equipment in which the module is to be installed.
- all the appropriate tools to disassembling the equipment
- suitable soldering iron and bits for working with surface mount devices.

Before attempting to fit this module study this manual thoroughly along with the service manual and circuit diagram for your equipment. Be careful not to move the wires on the module too much as this could lead to damage.

# Contents

<b>1. Introduction</b>	
1.1 NEDSP1061-KBD features	6
1.2 Limitations	6
1.3 Audio DSP noise cancellation	7
<b>2. Module description</b>	
2.1 Module layout	8
2.2 Connections	8
2.3 Electrical characteristics	9
2.4 Controls	9
2.4.1 <i>Input level</i>	9
2.4.2 <i>Output level</i>	9
2.4.3 <i>Beep volume level</i>	9
2.4.4 <i>Overload LED</i>	9
2.5 Module mounting	10
<b>3. Installation</b>	<b>11</b>
3.1 Introduction	11
3.2 Circuit location	11
3.3 Fitting	12
3.3.1 <i>Audio connections</i>	12
3.3.2 <i>Power connections</i>	13
<b>4. Setup</b>	<b>14</b>
<b>5. Troubleshooting</b>	<b>15</b>
<b>6. Operation</b>	<b>16</b>
6.1 Introduction	16
6.2 Operation	16
6.3 Demonstration mode	17
6.4 Notes about noise reduction	18
6.5 Noise reduction level	18

The keyboard is retained using the supplied 'Z' bracket, held in place by the loudspeaker clamp. Fix the dsp module to the inside of the lid using the self adhesive tape supplied.

Carefully replace the lid ensuring that none of the wires are trapped.

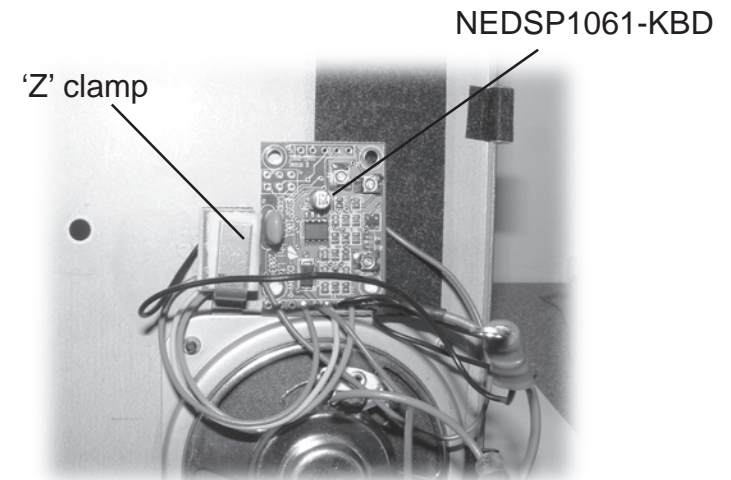
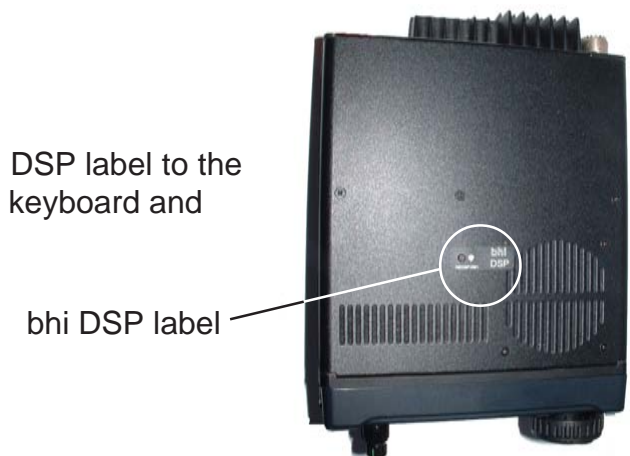

Figure 7. NEDSP1061-KBD module mounting.

Affix the bhi DSP label to the lid, over the keyboard and LED.



Drill the keyboard holes in the case lid as shown in the following diagram. Ensure the holes are de-burred.

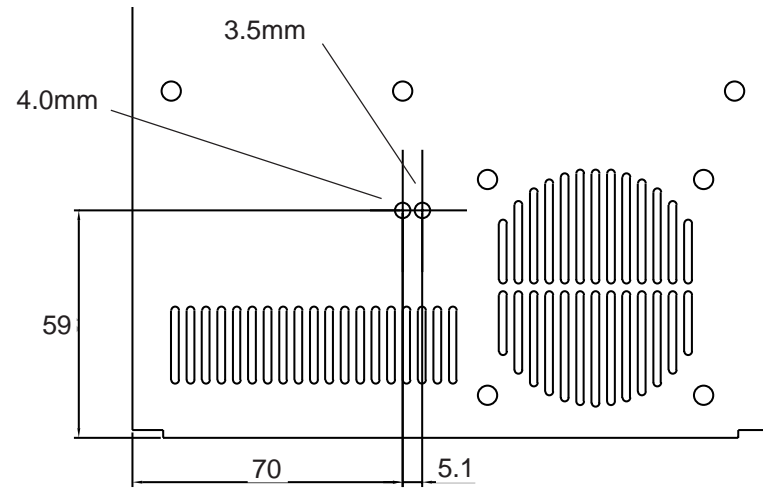

Figure 5. Case lid machining diagram

Connect the black power lead from the NEDSP1061-KBD module to the fan mounting screw, as shown in figure 6.

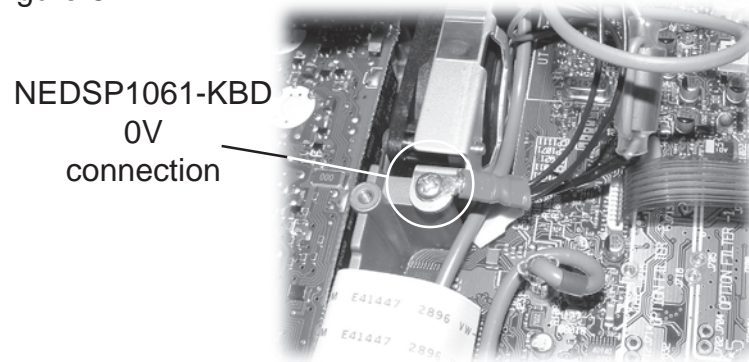

Figure 6. 0V connection from the NEDSP1061-KBD module.

## 7. Machining drawings

19

## Appendices

### Appendix A

Yaesu FT-817 fitting instructions

20

### Appendix B

Kenwood TS-50 fitting instructions

26

### Appendix C

Icom 706 MKII G fitting instructions

30

### Appendix D

Other bhi products

34

## 1. Introduction.

The NEDSP1061-KBD is a modular solution to noise reduction. It incorporates DSP technology to provide up to 35dB of noise cancellation. The module is controlled by a single pushbutton with LED indication for ease of use.

### 1.1 NEDSP1061-KBD module features:

- Fully adaptive to changing noise environments
- Input and output level controls
- Input overload indication
- Virtually no distortion to speech signal
- Up to 35dB of noise cancellation
- 4 or 8 levels of noise reduction selectable on power up
- 5 – 15V supply range
- 4.6dB on board gain
- Single key operation of all functions
- LED indication of DSP level and status
- Small size 26mm x 37mm

### 1.2 Limitations.

This module is designed to pass speech. Other signals such as data and music will to some degree pass through, but the integrity of these signals cannot be guaranteed.

This module is designed to be placed in a low level audio path only. The module will not drive a loudspeaker or other high power load (see bhi NEDSP1062 amplified DSP module).

The unit is single channel (mono).

Cut the white wire closest to the front of the transceiver.

Connect the NEDSP1061-KBD screened lead as follows:

Red wire to connector J1431

Blue wire to remaining end of the cut lead.

Screen - cut off.

Insulate both the connections with the supplied rubber sleeves.

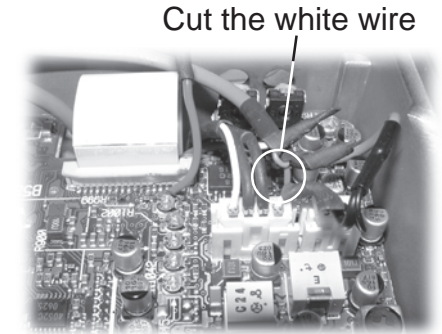

Figure 3. J1431 modified connections.

The red power lead for the NEDSP1061-KBD is connected to the PCB. Carefully remove the solder mask from the PCB surface in the position shown in figure 4. (it may be necessary to lengthen the lead).

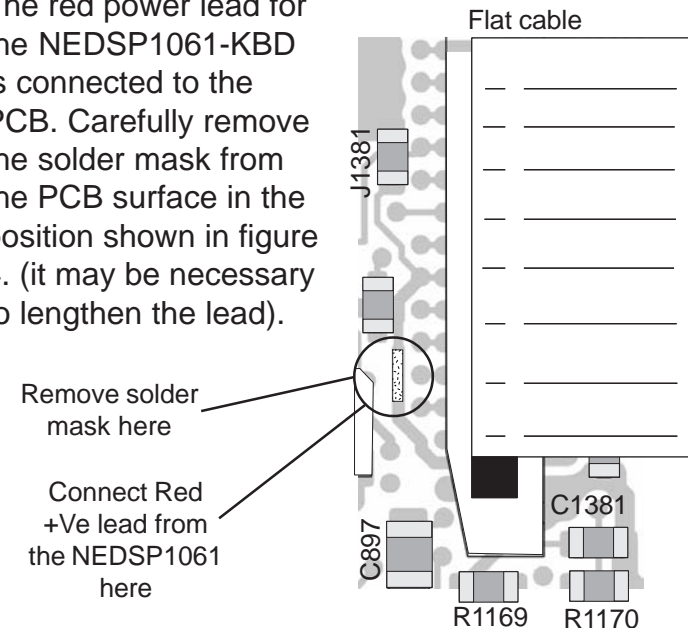

Figure 4. PCB modification for power lead

# Appendix C

## Icom 706 MKII G



This document should be read in conjunction with the relevant Icom 706 MKII G technical supplement. Disconnect the power before commencing.

Remove the 5 screws retaining the top cover. Disconnect all the loudspeaker connector. Remove the lid.

The NEDSP1061-KBD module is inserted into the audio path on the 4 pin connector J1431. This connector can be

located on the right hand side at the front of the main board.

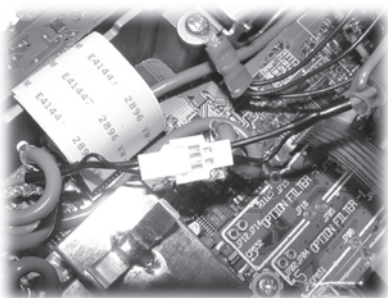
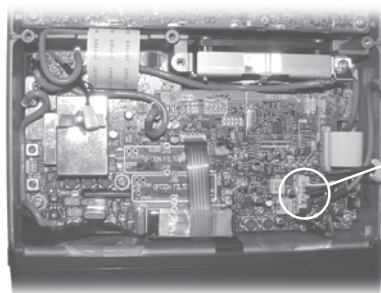

Figure 1. Loudspeaker connector



Audio connector

Figure 2. Location of connector J1431

This module is designed for communication type applications. The upper frequency limit is 4.5KHz and therefore not suitable for hi fidelity applications.

### 1.3 Audio DSP Noise cancellation.

The bhi DSP processes the incoming audio signal and then differentiates the speech from the noise. The unwanted noise and interference is then attenuated to leave only the speech.

The following diagrams are taken from actual audio signals and illustrate how the audio signal is being processed.

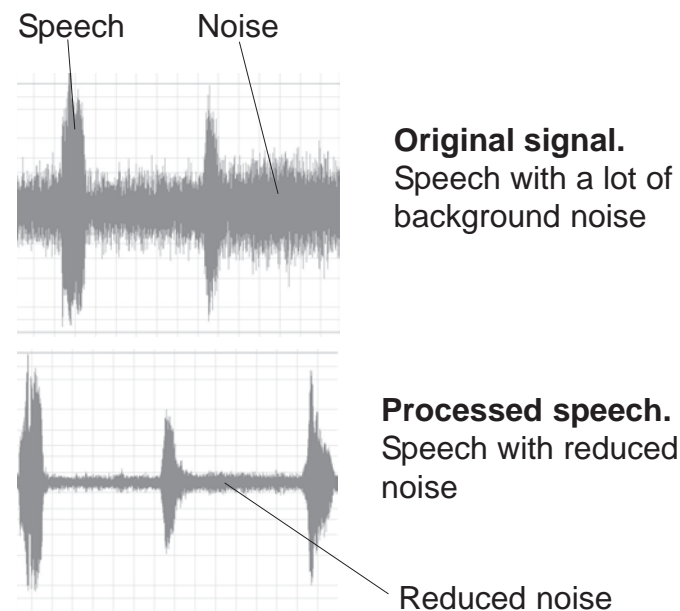

Figure 1. Noise cancellation.

## 2. Module description.

### 2.1 Module Layout.

The following diagram shows the layout of the NEDSP1061-KBD module.

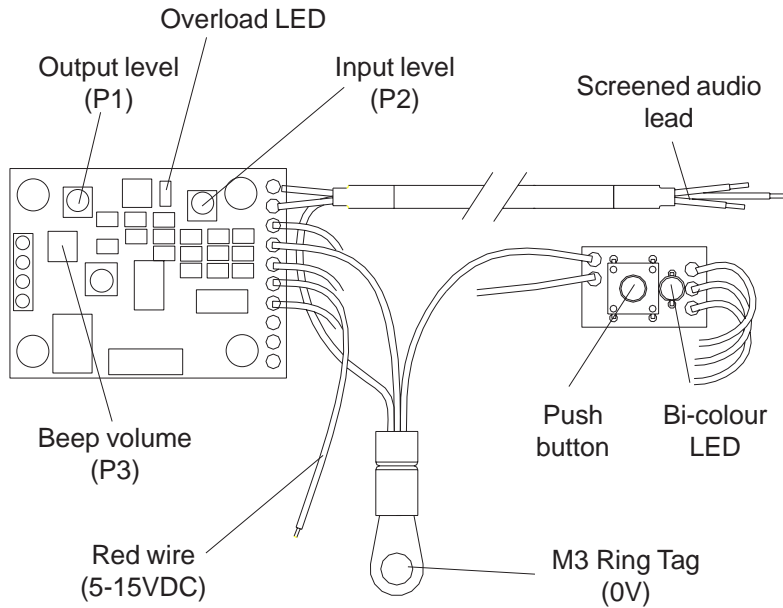

Figure 2. Module layout.

### 2.2 Module Connections.

The NEDSP1061-KBD module has five connections.

Red wire:	5 - 15VDC
M3 Tag:	0V
Screened Lead:	
Red	Audio In (to module)
Blue	Audio Out (from module)
Black	Audio Screen

14. Solder the screen from the DSP board to the ground on CN10 and insulate with tape.
15. Refit CN10 plug into CN10 socket.
16. Replace the speaker and speaker mounting bracket making sure no wires are getting pinched.
17. Place two thicknesses of double sided tape to the front right corner of the speaker bracket and mount switch PCB (see figure 5).
18. Connect radio to power and aerial and test DSP board works OK readjust beep, input and output levels if required. (Details in section 4 page 14)
19. Drill the top cover as detailed below.
20. Place the cover on the radio and check alignment of the switch and adjust if necessary.
21. Replace the top cover screws and fit the bhi label.

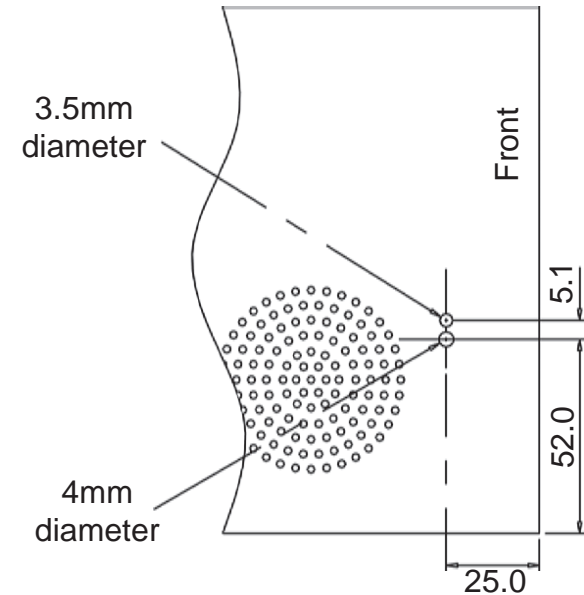

Figure 6. Switch mounting hole details.



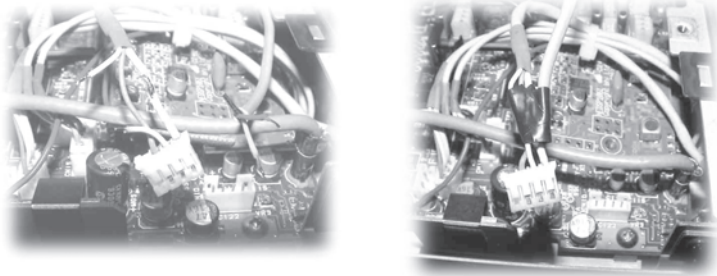

Figure 4. CN10 wiring detail.

10. Strip and tin the two ends of the clipped lead.
11. Remove some insulation from the CN10 ground wire and tin.
12. Solder the red audio wire from the DSP board to the lead coming out of the plug and insulate with tape.
13. Solder the blue audio wire from the DSP board to the remaining lead and insulate with tape.

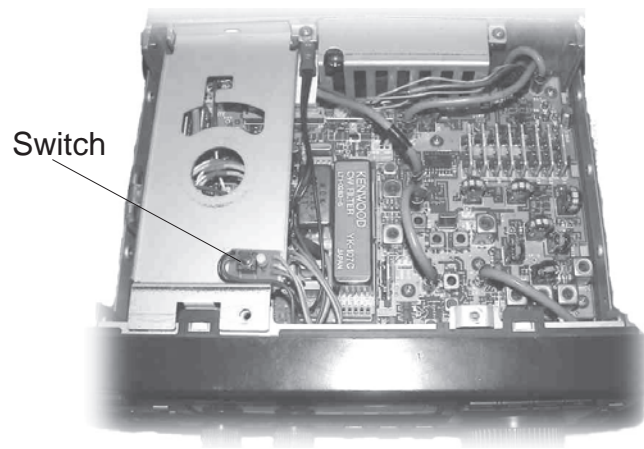

Figure 5. Switch mounting detail.

## 2.3 Electrical characteristics.

Electrical Characteristics					
Parameter	Description	Min	Typ	Max	Units
$V_{in}$	Supply voltage	5	9	15	V
$I_{in}$	Supply current		45	50	mA
In	Audio input signal	50	300		Vrms
Out	Audio output signal (1.7 Xs input max)			630	Vrms

Table 1. NEDSP1061-KBD Electrical characteristics

## 2.4 Controls.

Controls are provided to allow the NEDSP1061-KBD to be integrated in to the target system. 3 level controls are provided.

### 2.4.1 Input Level:

To set the audio level to the optimum level for the DSP.

### 2.4.2 Output Level:

To match the output level of the DSP module to that of the following stage.

### 2.4.3 Beep volume level:

Allows the user to adjust the beep volume control to suit. The beep volume can be reduced to zero if required.

The modules are factory set to the maximum level.

Turning the potentiometers anti clock wise will increase the levels.

*Note: The potentiometers do not have end stops. It is possible to set the potentiometer in a dead band between the ends, resulting in the audio being lost, continue rotating and the audio will return.*

#### 2.4.4 Overload LED.

The overload LED circuit monitors the amplitude of the audio level entering the DSP module. The LED will illuminate when the amplitude exceeds the maximum permitted level. If the amplitude is increased further the DSP will clamp the audio signal to prevent damage to the DSP input. This will cause the audio signal to become distorted. The optimum level is achieved when the loudest peaks of the input audio, just cause the LED to glow.

#### 2.5 Module mounting.

The DSP module has four mounting holes that can be used to retain the unit inside the equipment. Alternatively a self adhesive pad is supplied to allow the module to be mounted in a convenient position - without the need for drilling.

Two holes need to be drilled in the casing of the equipment for the keyboard. Hole sizes and positions can be found in section 7 - page 19.

The keyboard can be retained using the supplied 'Z' bracket or alternatively retained using a suitable adhesive, or the mounting pads supplied.

In some equipment it may be possible to clamp the bracket under the loudspeaker bracket (e.g. FT-817)  
Cover the keyboard holes with the supplied self adhesive label.

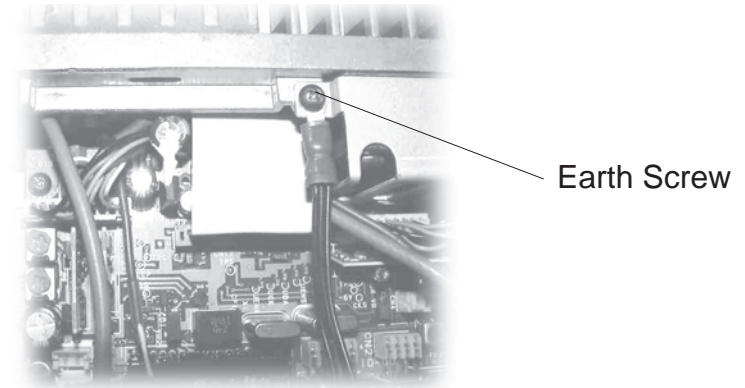

Figure 2. Location of earth point.

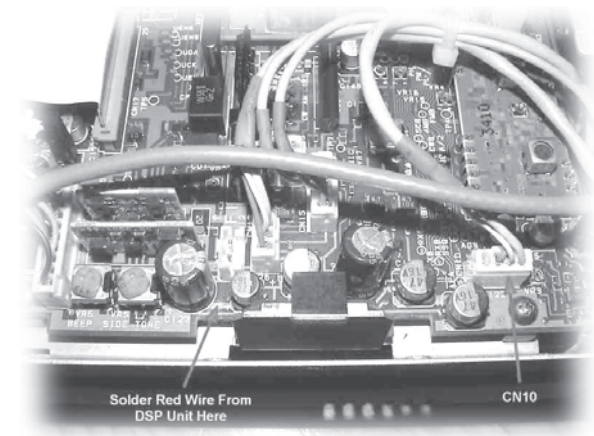

Figure 3. Position of red wire.

7. Carefully scrape the solder mask off the track to expose the copper.
8. Solder the red lead of the DSP board to this point.
9. Remove the plug from CN10 and clip the white wire that is next to the ground in the middle.

## Appendix B Kenwood TS50

Have the front of radio facing you and refer to the photographs in this manual to assist with the board installation.

1. Remove the top cover from the radio.
2. Remove speaker and speaker mount.
3. Fix double sided tape to the bottom of the DSP board (DSP chip side) making sure the tape lines up with the edges of the board.
4. Fit the DSP board as shown in figure 1.

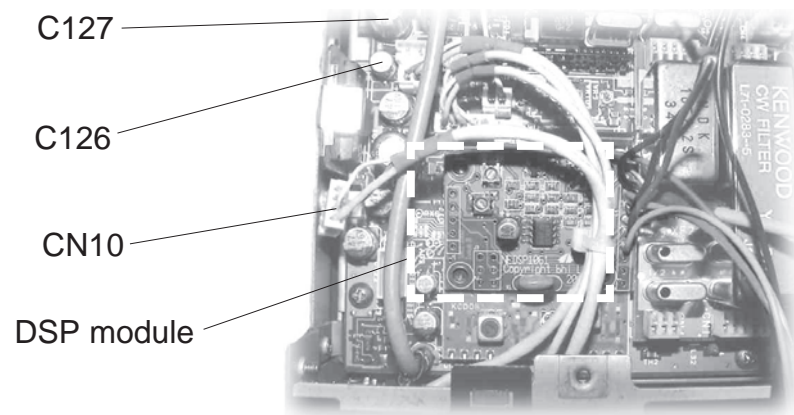

Figure 1. Location of C126,C127, CN10 and DSP module

5. Remove the mounting screw for the fan and attach the ground lug at this point.
6. Locate the pc board trace coming from pin 8 of the audio amp chip (IC7) This track is between C127 elect cap and C126 elect surface mount cap. There is a + printed on top of this track for C126 (see figure 1).

## 3. Installation

### 3.1 Introduction.

Before commencing installation study the equipment's service manual/circuit diagram thoroughly to familiarise yourself with the circuit diagram and disassembly procedure. Detailed information for fitment into specific equipment is available in the appendices of this manual.

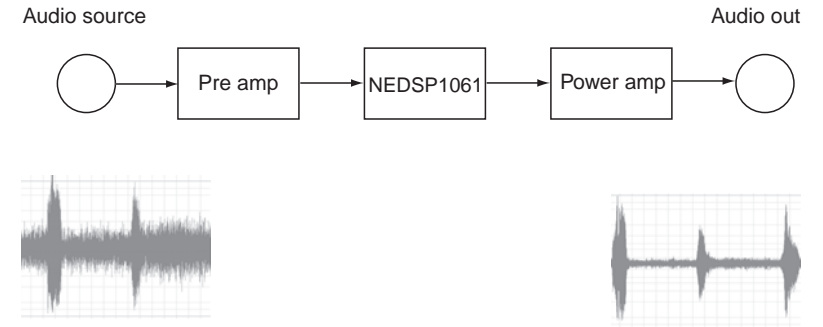

Figure 3. Basic connection diagram

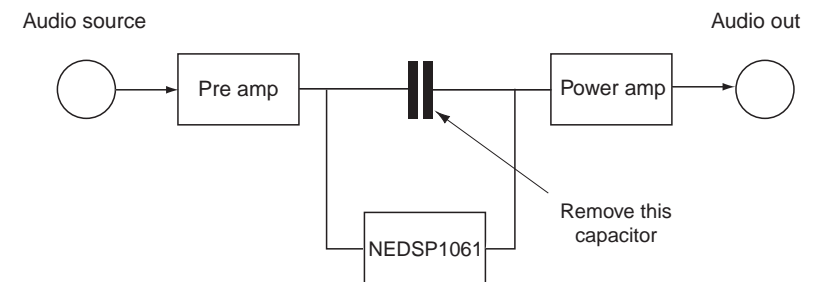

Figure 4. NEDSP1061-KBD Audio path

For optimum performance provide the module with a constant amplitude signal, for example before the volume control.

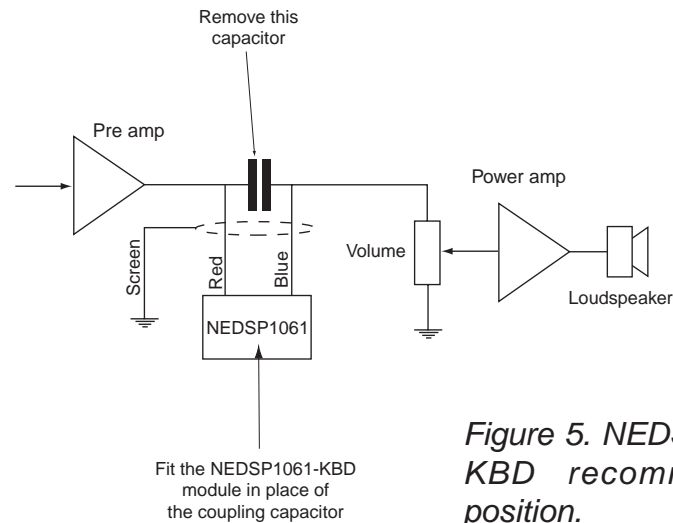

Figure 5. NEDSP1061-KBD recommended position.

#### Note:

On some modern receivers/transceivers the volume control is digital and doesn't operate in the audio path. Contact the manufacturer for advise for the most suitable position for the DSP module..

### 3.3 Fitting.

After locating a suitable location for the module in the circuit, refer to the service manual for disassembly information.

#### 3.3.1 Audio connections.

Carefully remove the chosen coupling capacitor, taking care to not damage the PCB pads. Solder the blue wire from the screened lead to the power amp side of the capacitor and the red to the other.

The black wire should be connected to a convenient 0V

#### Keyboard mounting using the 'Z' bracket.

- Slacken the screws retaining the loudspeaker
- Position keyboard into the lid cutouts
- Place the 'Z' bracket over the keyboard, carefully easing the bracket into position
- Retighten the loudspeaker bracket.

Clamp 'Z' bracket

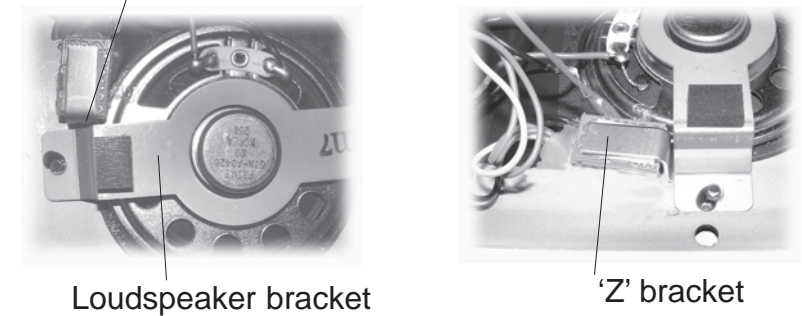

Figure 4. Keyboard mounting

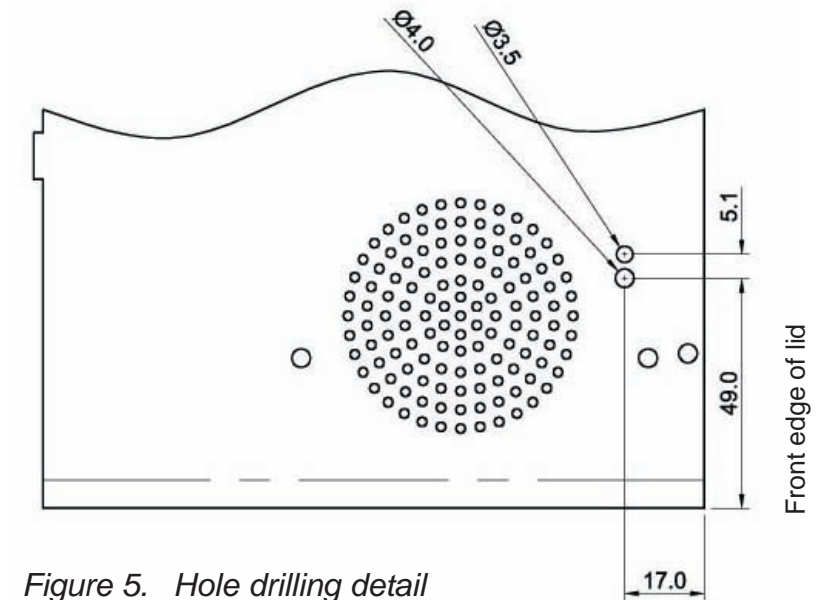

Figure 5. Hole drilling detail

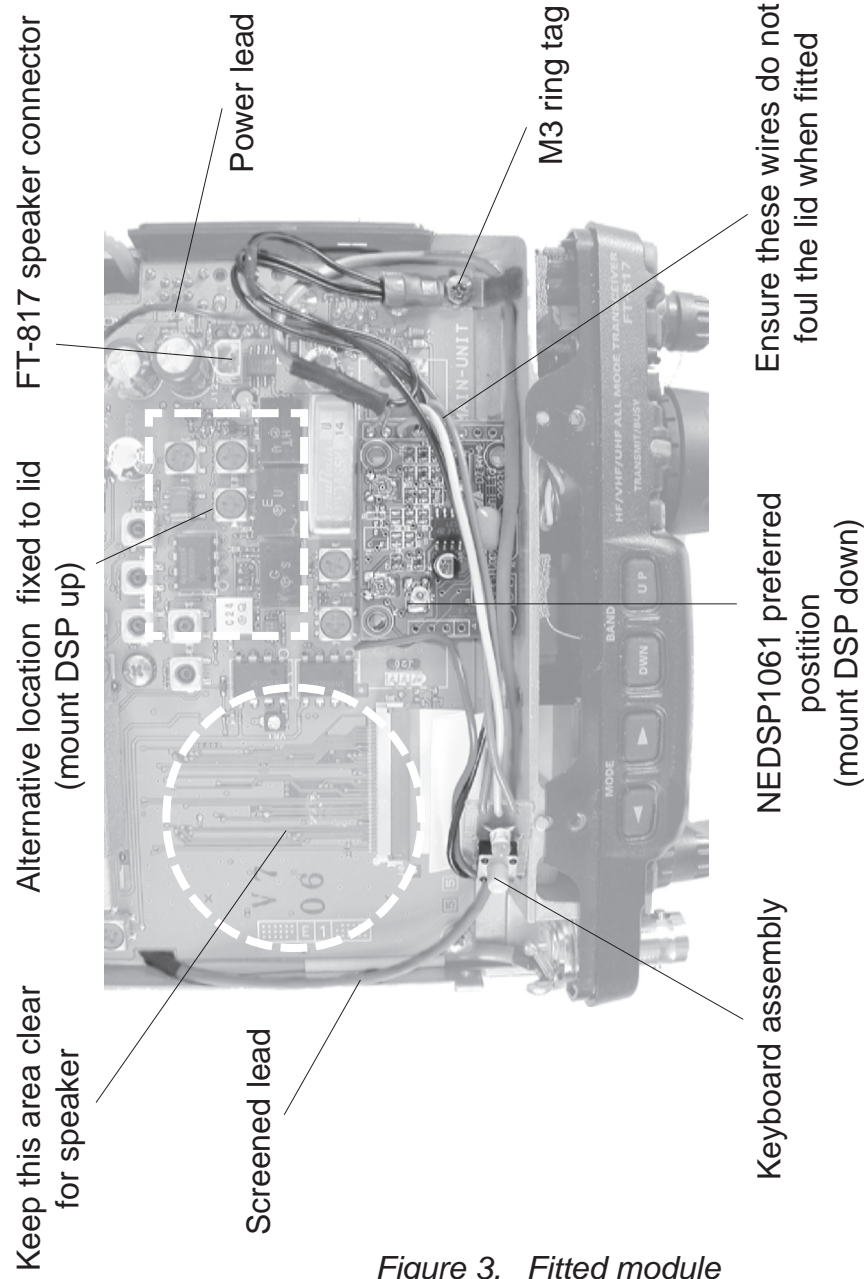

Figure 3. Fitted module

connection (this screens the cable and acts as a mechanical fixing for the cable, protecting the capacitor pads).

3.3.2 Power connections.

5 - 15VDC (9V typically) is required to operate the module. The lower the voltage, the less heat the module will have to dissipate.

Locate a convenient point to connect the power. Ensure that this point is connected after the power switch, otherwise the DSP module will be drawing power all the time, and may discharge the batteries (where fitted). Connect the red wire to this point.

The 0V connection is formed using the M3 ring tag. Locate a suitable 0V point (such as a PCB retaining screw that is fixed into the chassis).

When routing the wires, ensure they are away from strong sources of RF or high voltage.

## 4. Setup

---

The levels come factory set to the maximum position. This should be adequate for most applications. However the module can be adjusted as follows.

Tune the equipment to a strong signal.  
Switch off the noise reduction (LED should illuminate orange or red).

Adjust the input P2 until the overload led illuminates.  
Back off the potentiometer approximately a 1/4 of a turn.

Adjust P1 to give the correct listening volume, without distortion.

Adjust P3 to give the desired beep volume level, or off if required.

Replace the main unit PCB.  
The NEDSP1061-KBD screened lead fits in the cut out provided for the front antenna connector.

Replace the main unit, connections, and all screws except the front right hand screw.

Drill the holes for the lid, as per the drawing on page 25 of this manual.

The keyboard is mounted using the supplied 'Z' bracket. See page 25 for more information on installing the bracket. Alternatively use hot melt, epoxy or any suitable adhesive affix the small keyboard to the inside of the lid. Taking care to not get adhesive on the upper surface of the lid, switch or LED.

Allow this to cure before continuing.

The NEDSP1061-KBD can be affixed in two positions. The preferred position is in the location of the optional filter. This provides the more mechanically secure location. If the optional filter is (or is going to be) installed the module can be installed on the inside of the lid (see photo).

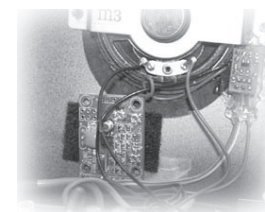

Solder the red (power) lead to the drain of Q1082 (TP1084).

Connect M3 ring tag (0V leads) using the right front screw.  
Affix the NEDSP1061-KBD module using the supplied self adhesive pad in the chosen location.

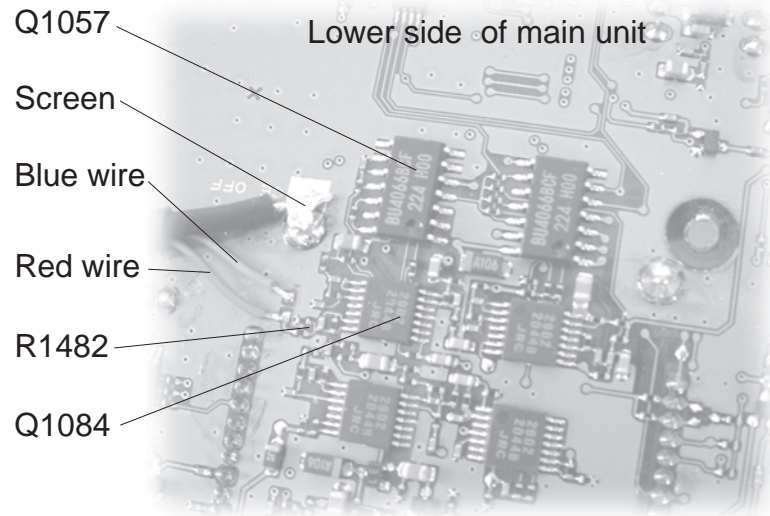
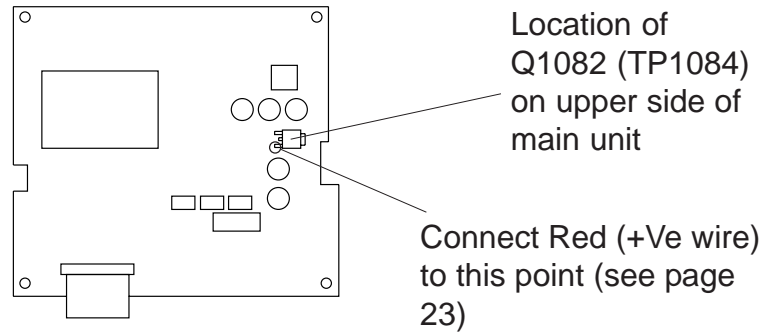
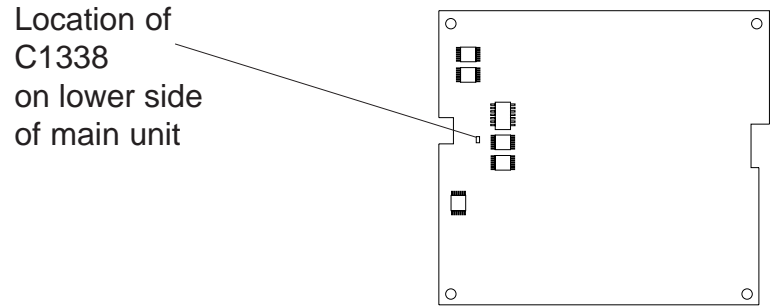

Figure 2. NEDSP1061-KBD connection detail

## 5. Troubleshooting

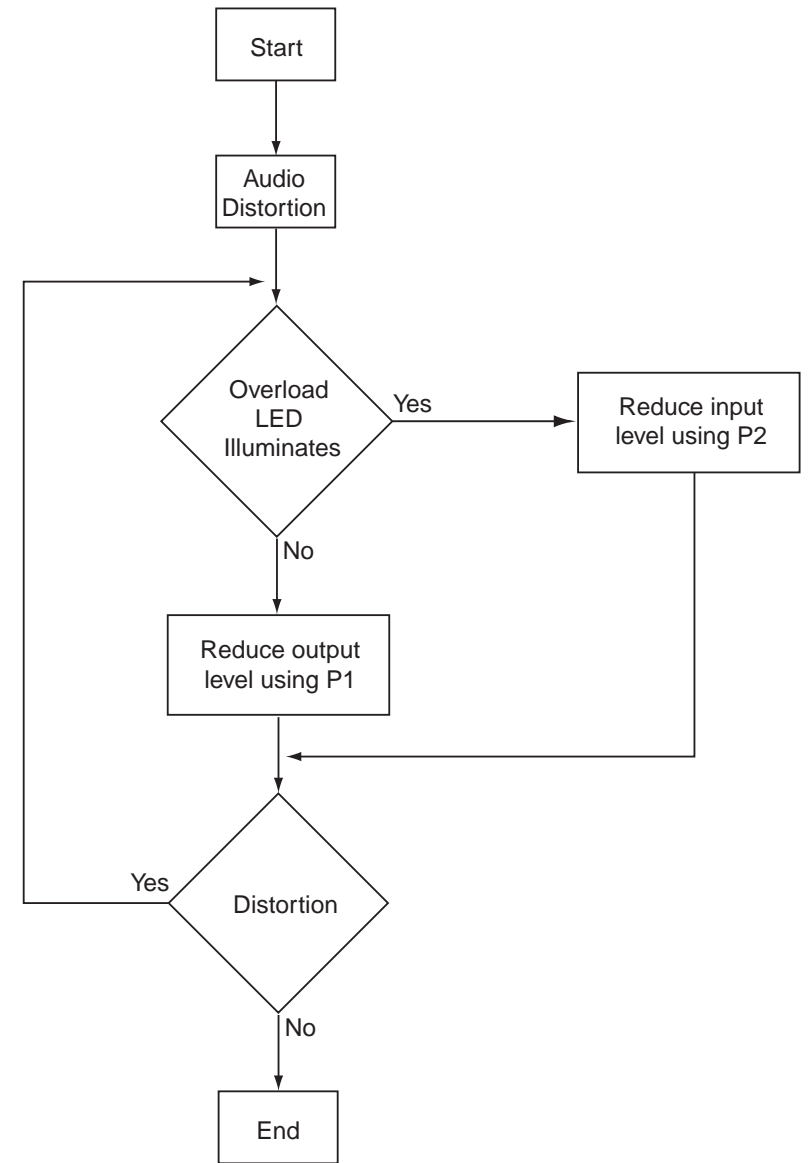

Figure 6. Troubleshooting flowchart.

## 6. Operation

### 6.1 Introduction.

All functions of the NEDSP1061-KBD are controlled by a single button.

- Single press turns the noise cancellation on/off.
- Holding down the button changes the DSP filter level.

The mode of operation is indicated both visually and audibly.

The LED is illuminated red for 4 level mode, or orange for 8 level mode when the noise cancellation is off, and not illuminated when the noise cancellation is on in 8 level mode to save on battery life. The LED is green when the filter is on in 4 level mode.

When the noise cancellation level is changed the LED will flash green to indicate which level has been selected, and simultaneously the DSP will beep to give audible indication of DSP level. This allows the operator to change the DSP level without having to look at the LED to see which level has been selected.

A short beep is emitted to acknowledge a button press. The module will store the current DSP level, and will return to this level when the equipment is switched on, but always in the off position.

### 6.2 Operation.

Switch on the equipment.

The LED will illuminate red or orange to indicate that the noise cancellation is off. The unit will flash/beep to indicate the DSP filter level last used.

To place the module into the audio path it is necessary to remove the audio signal coupling capacitor C1338.

The following diagram shows the position of the component.

Carefully remove the capacitor.

Connect the screened lead from the NEDSP1061-KBD module as follows:

- Red lead - to R1482 side of C1338 (audio in)
- Blue lead to the other side of C1338 (audio out)
- Screen to the grounded connection close to the capacitor.

See figure 1 below for details.

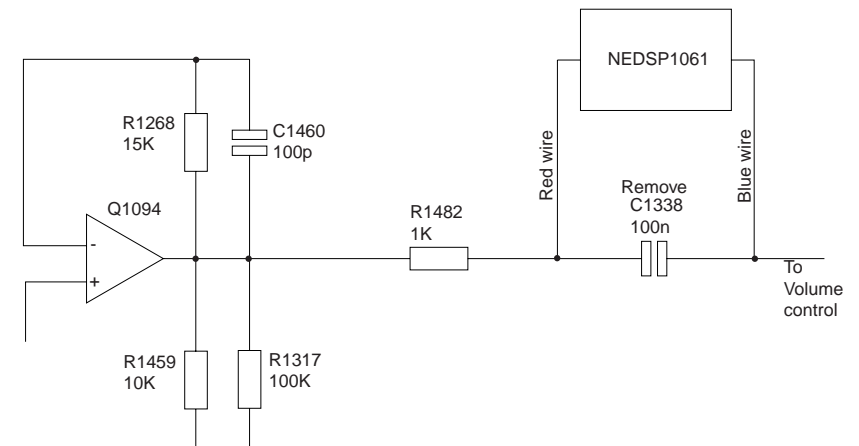

Figure 1. Schematic detail. FT-817



## Appendix A Yaesu FT-817



This document should be read in conjunction with the relevant Yaesu FT-817 technical supplement or service manual.

The bhi NEDSP1061-KBD module is inserted into the audio path of the transceiver, at a point before the volume control. To access this point it is necessary to remove the main unit.

Remove any fitted batteries or NiCad pack before commencing installation.

Remove the top and bottom covers.

Remove the 5 main unit fixing screws.

Disconnect all connections - apart from the front unit ribbon cable.

Hinge the main unit forward, over the front unit ribbon cable.

**Noise cancellation on/off:** Press and release the button and the LED will go off indicating that the noise cancellation is activated (green in 4 level mode). A short beep will acknowledge the key press.

**Changing the filter level:** Hold down the button. The led will flash the filter level, and if the button is held it will step through all the levels (4 or 8 depending on which mode you are in), audio beeps also indicate the filter level. Release the button to select a level. This new level will be stored in memory and will be the default setting the next time the unit is powered up (always powers up with noise cancelling off).

### 6.3. Demonstration & Setup modes.

The NEDSP1061-KBD module features 2 preset demonstration modes, and the ability to select 4 or 8 filter levels. The demo modes show the noise cancellation abilities of the NEDSP1061-KBD module. To listen to the demonstration modes, or change the number of DSP levels it is necessary to put the module into the set up mode:

#### 6.3.1 **Demonstration 1:**

Hold down the button and switch on the equipment. You will hear a 2 tone beep. Release the button now for demonstration mode 1.

The module will switch the noise cancellation on for 1.5 seconds, then off for 1.5 seconds. It will then move onto the next level and repeat this continuously through all 4 levels. This mode a particularly effective when the equipment is just receiving static, as it demonstrates the attenuation of white noise at all the levels.

Alternatively tune the equipment into a good quality FM speech broadcast. This demonstration shows how little the DSP alters the speech, at any of the levels.

### 6.3.2 **Demonstration 2:**

Follow the procedure for 6.3.1. Wait for the second 2 tone beep, then release the key.

In this mode the filter level is set to level 3.

The noise cancellation is switched on for 3 seconds, then off for 3 seconds. This loops until the user aborts this mode. This is a good demonstration for listening noisy SSB conversations showing the before and after.

### 6.3.3 **Filter Level Select:**

After the 3rd two tone beep the filter level pre-sets at level 4 in 8 level mode, release the button to select this mode. After the fourth 2 tone beep the module enters the filter level select mode. Release the button after either the 4 or 8 beeps to select the desired level mode. The module will return to normal operation after this, or hold down the button until the 2 tone beep is heard. Release the button, after a short delay the LED will flash indicating the stored level, as during the normal switch on.

### 6.4 **Notes about the noise reduction.**

When using the module on level 4/4 or level 8/8 some distortion may be heard. This is quite normal when listening to weak signals with high levels of noise present.

### 6.5 **Noise reduction levels.**

Level (4)	Level (8)	Tone Reduction	White Noise Reduction
	1	4dB	9dB
1	2	5dB	11dB
	3	6dB	13dB
2	4	8dB	15dB
	5	16dB	17dB
3	6	21dB	20dB
	7	25dB	24dB
4	8	65dB	35dB

## 7. Machining details

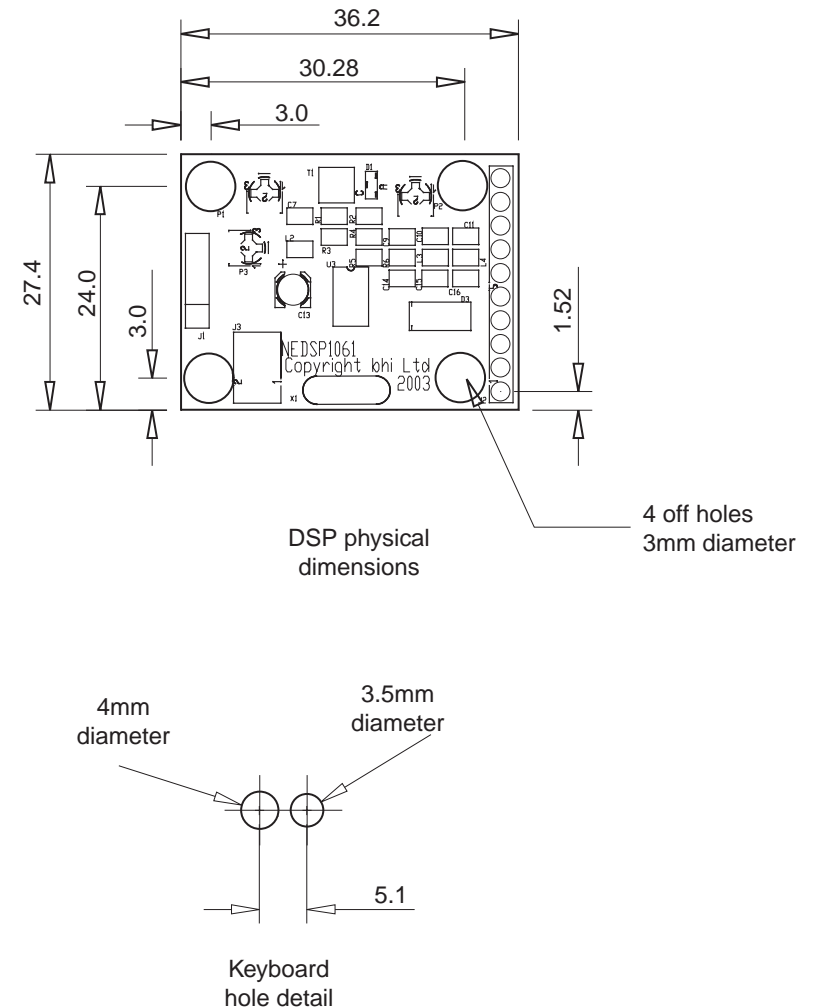

Figure 7. Hole machining details.